

Blue Sky International | "The Stand"

Fully Adjustable Nearfield Monitor Support System



Owner's Manual and Assembly Instructions



In a policy of continuous product development, blue sky international reserve the right to change features and specifications without notice.
Copyright © blue sky International, 2004. All rights reserved

This document is issued by:
Blue Sky International
70 Sea Lane, Farmingdale, NY 11735 USA
T: 516 249 3662 F: 516 249 8870
E: info@abluesky.com
Web: abluesky.com

ATTENTION! SAFETY INSTRUCTIONS: READ INSTRUCTIONS - Read all assembly and installation instructions prior to using this product. RETAIN INSTRUCTIONS - Retain these safety and operating instructions for future reference. HEED ALL WARNINGS - Follow all warnings in this manual regarding this product and only use as intended. FOLLOW INSTRUCTIONS - Carefully follow all operating and use instructions. PLEASE NOTE: Every effort has been made to provide accurate and error-free assembly and installation information. Blue Sky International disclaims liability for any difficulties arising from interpretation of information contained in these instructions. Blue Sky International can not reasonably assume responsibility or liability - direct, indirect or consequential - for the structural integrity or suitability of any non Blue Sky speakers or products; nor the structural integrity of where this product is used.



CONTENTS

1. Safety Instructions
2. Contents
- 3

Cover / P.1
P.2

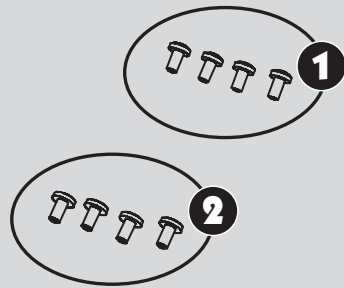
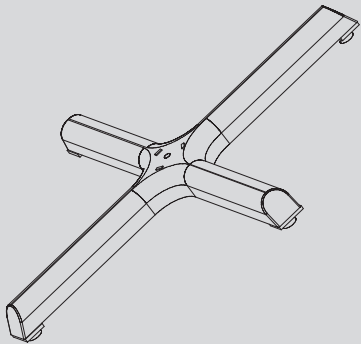
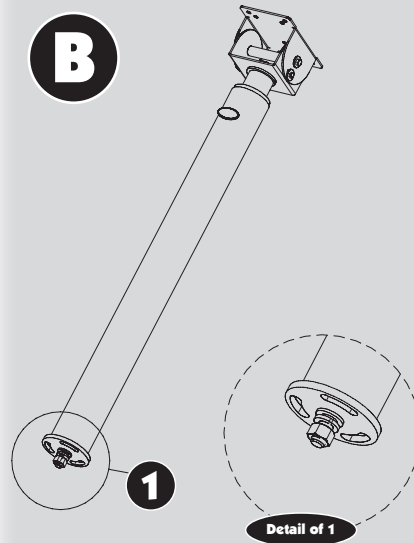
A**C****B**

PARTS LIST

Below you will find a list of items included with Blue Sky's "The Stand". "The Stand" ships in two boxes, one which includes these instructions, the leg assembly and the screws, the second box includes the base. To the left are drawings which describe the included items. The optional universal adapter plate ships in a separate box.

Figure A: Screws

1. Four 1/4 x 20 x .5" screws for the SAT 6.5
2. Four M6 x 1 x 12mm metric screws for the SAT 5

Figure B: Leg Assembly

- 1: Detail of 1 - shows the black spacer disc, flat washer, lock washer and nut (19mm).

Figure C: Base for "The Stand"

REQUIRED TOOLS

Only two tools are required to assemble the stand and adjust the angle of the bracket. You will need one **medium size Phillips head screwdriver** and an **adjustable wrench**.

Additionally, we highly recommend that a second person is available to help mount the speaker to the stand. This person can help to stabilize the stand and the speaker until it is securely attached. This will minimizing any chance of damage or injury.

D

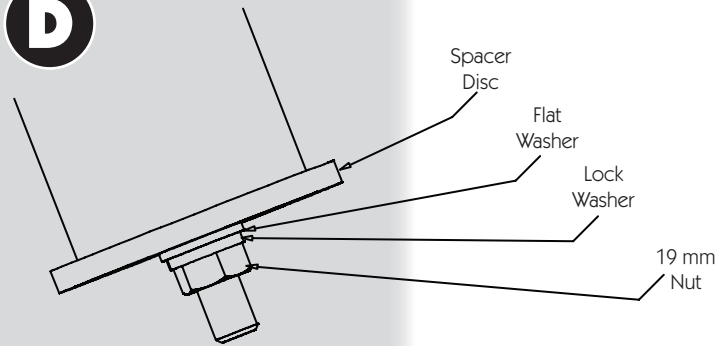

IMPORTANT: Prior to starting assembly, read all of the instructions and confirm that you have all the necessary tools and parts. Additionally, confirm that the area where “The Stand” will be placed is level and solid enough to support the combined weight of the stand and the speaker. Finally, prior to mounting any speaker onto the stand, confirm that the stand is solid and assembled correctly.



Align slots with holes in spacer

E

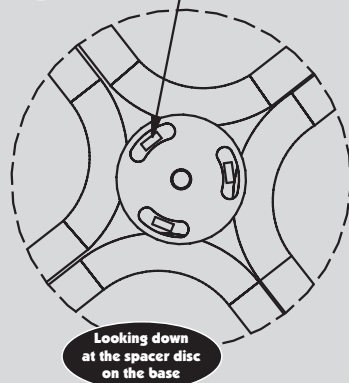

F

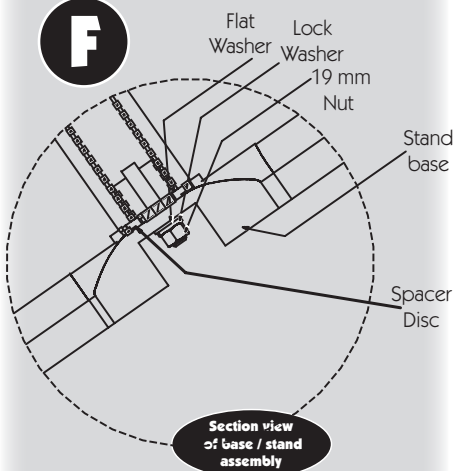

“The Stand” Assembly Instructions

Attaching the leg assembly to the base

1. Remove bolt, washers and spacer disc from the bottom of the leg assembly (**see figure D**).
2. Place spacer disc over the slots in the top of the base (**see figure E and F**).
3. Place threaded end of leg assembly through the hole in the black metal spacer disc and through the center hole on the base. (**see figure F**).
4. From the bottom of the base, place the flat washer over the threaded bolt protruding from the bottom of the base and then do the same with the lock washer. (**see figure F**).
5. Thread the supplied 19 mm nut onto the threaded bolt and tighten with a wrench until fully seated. NOTE - please confirm that the black metal spacer disc is properly seated before proceeding to the next step. (**see figure E and F**).

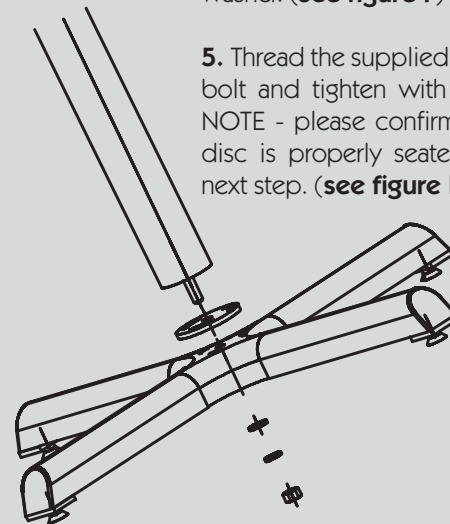

IMPORTANT: Prior to mounting any speaker to the stand, confirm that the stand is on solid and stable ground. Also, confirm that "The Stand" has been assembled properly, that the bracket is locked in place and that all parts are secure. Additionally, we highly recommend that a second person is available to help mount the speaker to the stand. This person can help to stabilize the stand, and the speaker until it is securely attached.

This will minimize any chance of damage or injury.



IMPORTANT: These instructions detail the assembly of "The Stand" and the mounting of Blue Sky International's SAT 5 and SAT 6.5, or the mounting of any speaker with an OmniMount Type 30 or 60 mounting pattern. The weight of any speaker being mounted using these instructions and the above mentioned mounting pattern, should not exceed 60 pounds. For speakers over 60 pounds, please see the instructions on page 5.



G

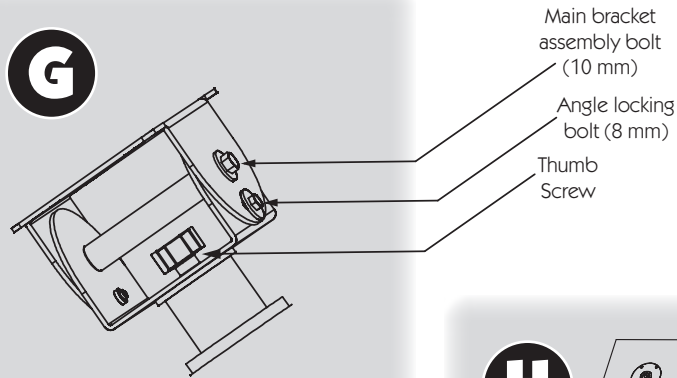

H

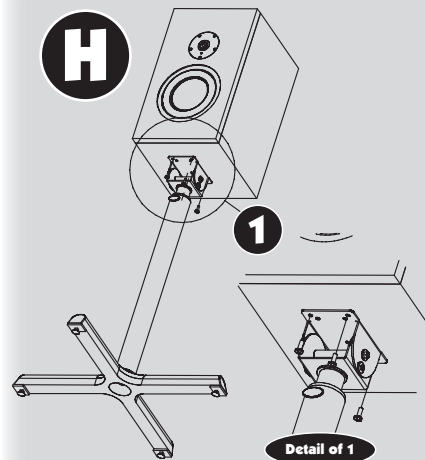

I



Blue Sky SAT 6.5 & SAT 5 / compatible speaker mounting instructions

Instructions for monitors with OmniMount Type 30 and Type 60 mounting patterns on the bottom. **Please read the important note above prior to starting.**

1. Confirm that both of the "main bracket assembly bolts" are firmly in place and fully tightened (**see figure G**).
2. Align the top of the bracket so that it is level and then tighten both of the Angle Locking Bolts so that the bracket doesn't move in the vertical plane (**see figure G**).
3. Confirm that the thumb screw is tightened and that the entire bracket assembly is fastened properly to the main leg assembly (**see figure G**).

Note: A speaker attached to The Stand can either be angled up or down vertically depending on how its mounted to the bracket. Confirm that you are mounting the speaker so that it works best for your application (see page 7 for more information).

4. With the help of an assistant, carefully place the speaker on top of the stand and have the assistant support the speaker until it is firmly attached to the stand. Center the speaker and align the insert holes on the bottom of the speaker with the holes on the bracket. (**see figure G**)

5. Make sure to use the correct screws for the inserts on the bottom of your speakers (page 3 Parts List). Insert the screws through the hole in the bracket and into the inserts on the bottom of the speaker. Thread the screws into the inserts, being careful not to cross thread the screws. Tighten down the screws in a crisscross pattern until the screws are firmly seated. (**see figure G - detail 1**)

6. The stand is now fully assembled, see section **Page 7** for details on how to adjust height, tilt angle or rotation.

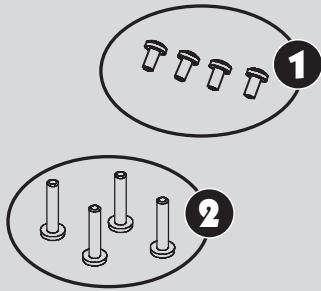
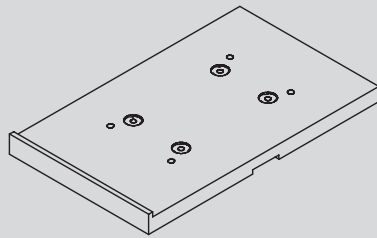
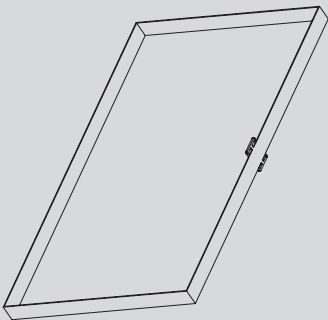
J**K****L**

OPTIONAL UNIVERSAL ADAPTER PLATE **PARTS LIST**

Below you will find a list of items included with Blue Sky's "The Stand". "The Stand" ships in two boxes, one which includes these instructions, the leg assembly and the screws, the second box includes the base. To the left are drawings which describe the included items. The optional universal adapter plate ships in a separate box.

Figure J: Screws

1. Four 1/4 x 20 x .75" to attach the plate to The Stand.
2. Four 1/4 x 20 x 1.25" to attach plate to any monitor with compatible inserts.

Figure K: One Universal Adapter Plate

Figure L: One Safety Strap

REQUIRED TOOLS

You will need one **medium size Phillips head screwdriver** to attach the Universal Adapter Plate to an already assembled stand.

Additionally, we highly recommend that a second person is available to help mount the speaker to the stand. This person can help to stabilize the stand and the speaker until it is securely attached. This will minimizing any chance of damage or injury.



IMPORTANT: Prior to mounting any speaker to the stand, confirm that the stand is on solid and stable ground. Also, confirm that “The Stand” has been assembled properly, that the bracket is locked in place and that all parts are secure. Additionally, we highly recommend that a second person is available to help mount the speaker to the stand. This person can help to stabilize the stand, and the speaker until it is securely attached. This will minimize any chance of damage or injury.



IMPORTANT: The weight of any speaker being mounted using these instructions must not exceed 80 pounds. These instructions detail the mounting of speakers up to 80 pounds in weight without mounting inserts, or those speakers with OmniMount 120 mounting patterns. Speakers mounted to the stand must have a low center of gravity and the load must be centered over the stand.



M

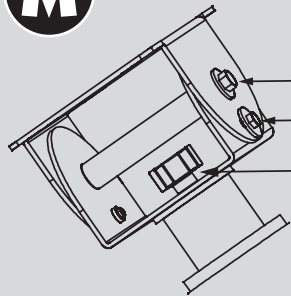

Main bracket assembly bolt (10 mm)

Angle Locking bolt (8 mm)

Thumb Screw

O

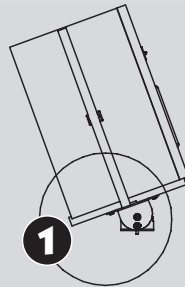

1

Safety Strap

Safety Strap Slot

Plate Lip

N

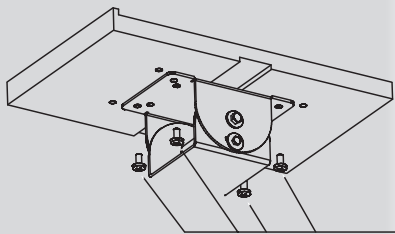

1/4 x 20 x .75" Screws (short)

Speaker mounting instructions using the **OPTIONAL Universal Adapter Plate**

Instructions for mounting monitors up to 80 pounds in weight. **Please read the important note above prior to starting.**

1. Confirm that both of the “main bracket assembly bolts” are firmly in place and fully tightened (**see figure M**).
2. Align the top of the bracket so that it is level and then tighten both of the Angle Locking Bolts so that the bracket doesn’t move in the vertical plane (**see figure M**).
3. Confirm that the thumb screw is tightened and that the entire bracket assembly is fastened properly to the main leg assembly (**see figure M**).

Note: A speaker attached to The Stand can either be angled up or down vertically depending on how its mounted to the bracket / Universal Mounting Plate. Confirm that you are mounting the speaker so that it works best for your application (see page 7 for more information).

4. Place the Universal Mounting Plate on top of the bracket. The lip of the plate should be on the front of the speaker if it is going to be angled down and on the back, if it is going to be angled up (**See figure O, Detail 1**). Once the proper orientation has been determined, attach the plate to the bracket by inserting the included 1/4 x 20 x .75” (short) screws through the bracket and into the inserts on the adapter plate. (**see figure N**) Prior to tightening the screws see step 5.

5. Prior to tightening down the screws that attach the Adapter Plate to the bracket, feed the safety strap through the safety strap slot (**See figure O, Detail 1**). Once completed tighten down the screws and ensure that the Adapter Plate is firmly attached.

6. With the help of an assistant place the monitor on the adapter plate. Then using the included Safety Strap, firmly attach the speaker to the stand. See **Page 7** for details on how to adjust height, tilt angle or rotation.

P



Adjusting Stand Height

Adjustment of the height of the stand is very simple. First, place one foot on the base of the stand, then lift up on the bracket / monitor assembly until you have reached the desired height. Once you hear the cam engage, the monitor will stay at that height. To lower the stand, lift up on the bracket / monitor assembly until you have reach the maximum vertical excursion, then lower the speaker to the bottom, press down and you will hear the cam engage. You can now begin to raise the speaker again. (see figure P)

Adjusting Bracket / Monitor Angle

Using an adjustable wrench, loosen the Main Bracket Bolt and Angle Locking Bolt on either side of the bracket (**See figure Q, Detail 1**). Adjust the angle, then re-tighten the bolts firmly. Please make a note that the bracket only angles in one direction. If you need to angel the speaker up, instead of down, the speaker must be removed and remounted in the other direction. If you are using the universal adapter plate, please make sure that the lip of the plate is supporting the speaker properly (**See figure Q, Detail 2**).

Q

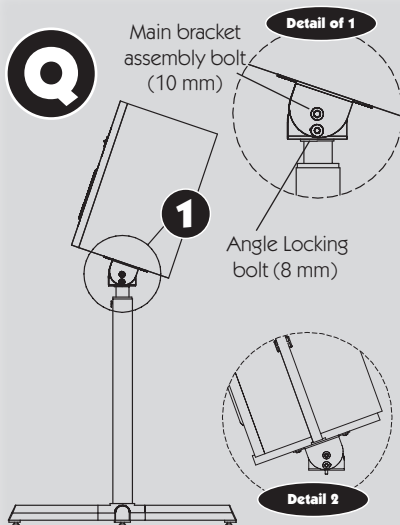

R

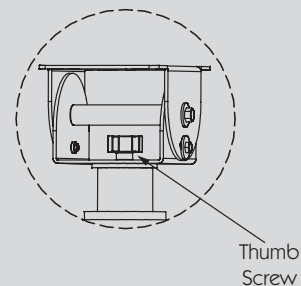

Adjusting Bracket / Rotation

To adjust the rotation of the bracket, slightly loosen the thumb screw in the center of the bracket (**See Figure R**). Rotate the speaker to the desired position, then firmly tighten down the Thumb Screw.

Factory Service Instructions

Service for the U.S. versions of Blue Sky products is available only from our authorized distributor, Group One Ltd., located in Farmingdale, New York. (Service for Blue Sky products outside the United States can be obtained through local dealers or distributors.) If your stand needs service, follow these instructions:

1. Review the manual and ensure that you have followed all setup and operating instructions.
2. Call (516) 249-1399 9:00am to 5:30pm EST and ask for Customer Service. Explain the problem and request an RA (Return Authorization) number. It is important to have your product serial number available when you call. You must have an RA number before you can obtain service.
3. Pack the product in its original packing material and box (do not return the manual). If you don't have the original packing material and/or box, please let Customer Service know when you call for the RA number. Blue Sky is not responsible for any damage that occurs due to non-factory packaging.
4. Include a legible note stating your name, shipping address (no P.O. boxes), daytime phone number, RA number, and a detailed description of the problem, including how it can be duplicated
5. Write the RA number on the top of the carton.
6. Ship the product to the address below. We recommend United Parcel Service (UPS). Please insure the product regardless of shipping method.

Blue Sky International
ATTN: SERVICE DEPT / RA#
70 Sea Lane
Farmingdale, NY 11735
USA

7. Turnaround time is three to five business days depending on the problem. When calling for RA numbers, please ask Customer Service what the turnaround time is. The serviced product will be sent back to you via the same shipping method as received (i.e. if you ship your monitor UPS Ground it will be returned UPS Ground, UPS Red will be returned UPS Red etc...). This only applies to products serviced under the warranty.



In a policy of continuous product development, blue sky international reserve the right to change features and specifications without notice.
Copyright © blue sky International, 2004. All rights reserved

This document is issued by:
Blue Sky International
70 Sea Lane, Farmingdale, NY 11735 USA
T: 516 249 3662 F: 516 249 8870
E: info@abluesky.com
Web: abluesky.com